



Control Panel

The gen-set control panel was designed to include, in one single panel, the switches, control devices and the protection devices. The components are the following :

- Engine cut-off module for automatic stop of engine in case of high water temperature, low oil pressure, high alternator temperature.
- Hour-meter.
- Start-stop button.
- Breaker for protection against of overload or short circuit.
- Thermal switch for D.C. electric circuit.

Engine

- Easy access in case of maintenance to the feeding system and lubrication, of the sea/water pump and the air filter.
- Safety stop in case of low oil pressure.
- Safety stop in case high water/exhaust gas temperature.
- Oil and fuel filters of easy access.

Alternator

- Synchronous, 4 poles, brush less self-excited, electronic voltage regulator (AVR).
- Rotor and stator coated with epoxy resin against external agents.
- Rotor dynamically balanced.
- Insulation class H.

Soundproof cabin

A new project engineering design with a structure of a draw piece of aluminum supporting, painted aluminum panels type 5754 of high resistance to external agents.

Good accessibility inside canopy, makes maintenance services more easy.

Engine	50 Hz
Model	Yanmar 3TNV88
Type	Diesel 4 stroke
Cylinders (nr.)	3
Cylinder block material	Cast iron
Bore (mm)	88
Stroke (mm)	90
Displacement (cc)	1642
Power (hp)	18,4
RPM	1500
Compression ratio	19,1:1
Combustion system	Direct
Engine head material	Cast iron
Speed governor	Centrifugal mechanical
Lubrication system	Forced
Oil sump capacity	4,8
Engine stop system	Stop solenoid
Fuel pump	Electric
Fuel pump discharge (cm)	70
Full load consumption (l/h)	4
Starting battery (Ah-V)	80 - 12
Battery charger (Ah-V)	40 - 12
Starter (kW-V)	1,2 - 12
Max. inclination	30°
Water pump flow (l/min)	25

Alternator	50 Hz
Type	Synchronous, 4-poles,self-excited
Cooling	Air
Voltage (V)	400
Frequency (Hz)	50
Max. power (kVA)	14,1
Continuous power (kVA)	12,7
Power factor (cos ϕ)	0,8
Insulating class	H
Voltage stability	$\pm 2\%$
Frequency stability	$\pm 5\%$

Cooling system

The cooling of the engine is based on a closed inner flow of coolant. The system is based on a cupronickel heat exchanger seawater/coolant type, where the thermal exchange occurs between coolant and seawater. Two separate pumps contribute to the flow of the coolant and the sea water.

50 Hz

Dimensions (Leng. x Width x Height)	1040 x 631 x 694 mm (with canopy)
Weight	344 Kg (with canopy)
Noise power level	52 dB _A at 7mt

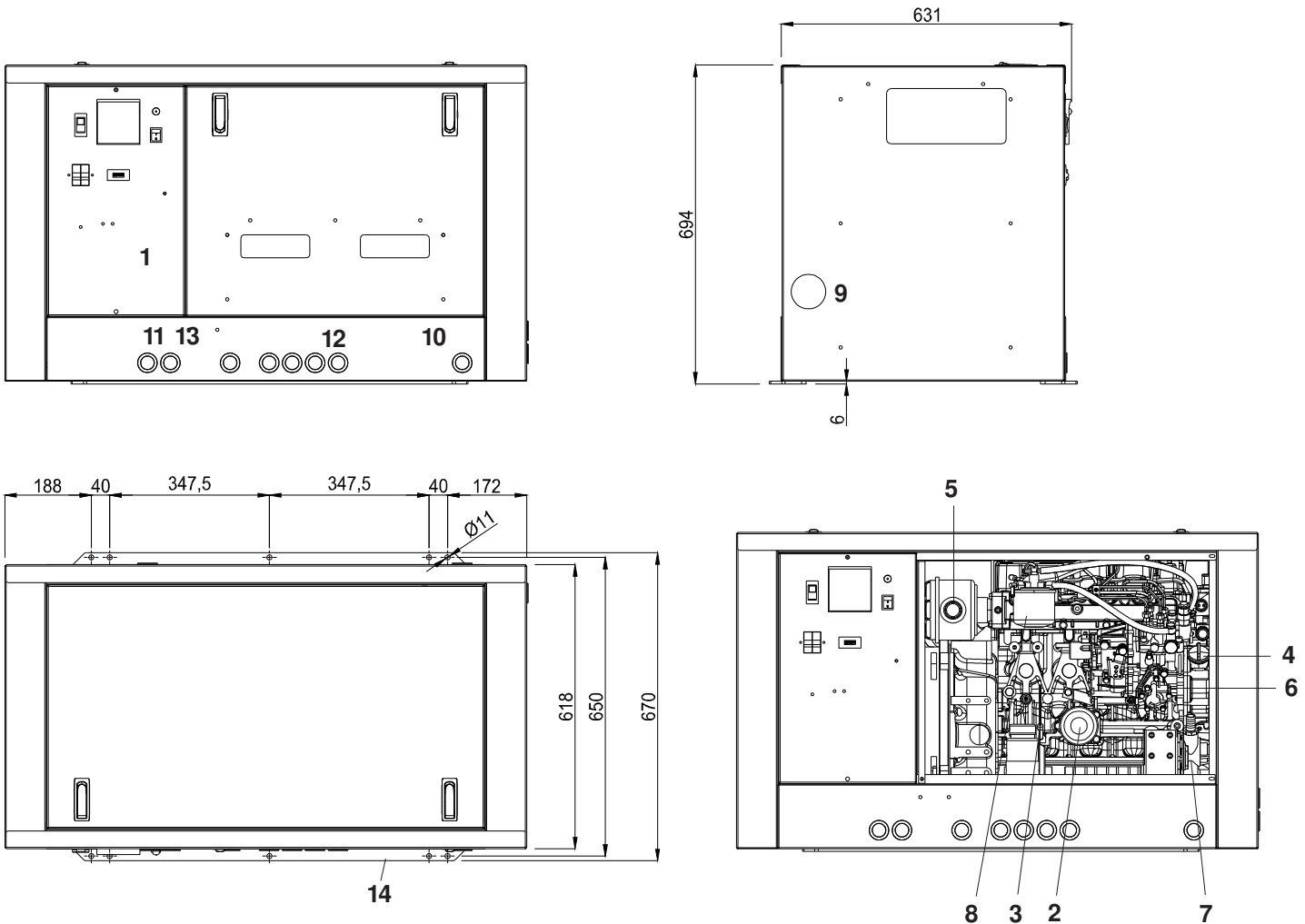

- 1 - Control panel
- 2 - Engine oil filter cartridge
- 3 - Oil dipstick
- 4 - Engine oil cap
- 5 - Air filter
- 6 - Closed circuit water pump
- 7 - Seawater pump
- 8 - Fuel filter
- 9 - Seawater exhaust connection (ø 50mm)
- 10 - Seawater inlet (ø 16mm)
- 11 - Battery connection
- 12 - Fuel tank connection (ø 8mm)
- 13 - Electric cables outlet
- 14 - Fixing brackets

FITTINGS

EXHAUST COMPONENTS KIT

SIPHON BREAK

WATER-GAS SEPARATOR KIT

STARTING REMOTE CONTROL PANEL WITH INSTRUMENTS

This drawing is only a reference and is not indicatly for the installation. For more information, you may contact your local dealer or GenSet generators S.p.A..

GenSet generators S.p.A. reserves the right to change the design or specifications without notice and without any obligations or liability whatsoever. For more information, you may contact your local GenSet dealer.

Dealer:

magnetron
 MARINE ELECTRONIC & ELECTRIC
 Magnetron d.o.o.
 Marina Dalmacija
 Bibinje-Sukošan
 tel. +385 98 210655
 info@magnetron.com.hr
 www.genset.hr